

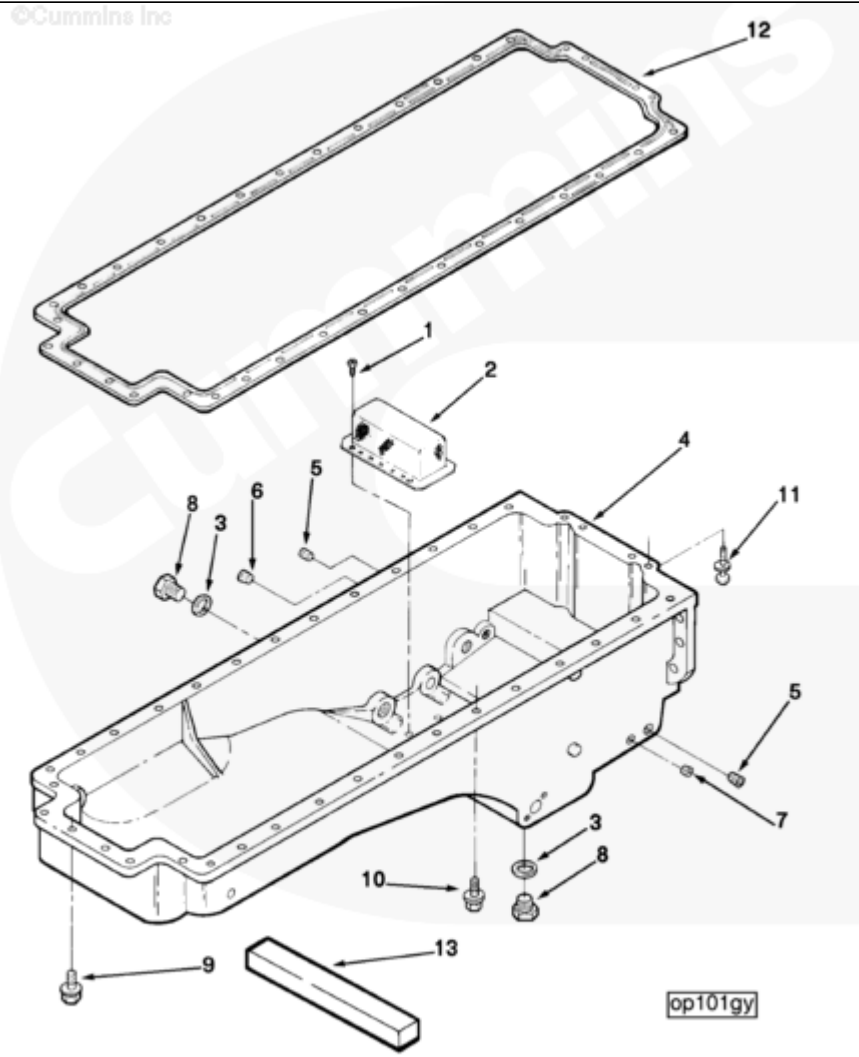

Parts Catalog - Option Detail

Electronic Parts Catalog - Option Detail				
Option	Group	Graphic	Film Card	Date
OP1115	07.01	op101gy	F	19-APR-94
Engines	NH/NT 855, NT495, NT743, NTA855 N106			



[SMALL](#) | [MEDIUM](#) | [LARGE](#)

Cart	Ref No	Part Number	Part Description	Required	Remarks
<input type="button" value="View My Cart"/>					
		OP1115	Oil Pan		

					Oil Pan
					Deep rear sump pan. 7 gallons
					(26.5L) high and 6 gallons
					(22.7L) low level. Angularity
					is 45 degrees front up,
					45degrees front down and
					45degrees side to side.
					Heater tap on exhaust side,
					1 NPTF. Bypass filter returns
					each side. Requires dipstick
					in hand hole cover.
<input type="checkbox"/>	1	S 1354	Self Tapping Metal Screw	4	10 - 16 X 3/8 in.
<input type="checkbox"/>	2	20622	Oil Suction Screen	1	
<input type="checkbox"/>	3	67946	Plain Washer	2	1 1/32 in.
<input type="checkbox"/>	4	193631	Oil Pan	1	
<input type="checkbox"/>	5	3008468	Pipe Plug	2	1/2 NPT.
<input type="checkbox"/>	6	3008470	Pipe Plug	1	1 NPT.
<input type="checkbox"/>	7	3013786	Pipe Plug	1	3/8 NPT.
<input type="checkbox"/>	8	3055069	Threaded Plug	2	1 - 18 UNS.
<input type="checkbox"/>	9	3017049	Captive Washer Cap Screw	4	7/16 - 14 x 2 1/8 inch
<input type="checkbox"/>	10	3008069	Captive Washer Cap Screw	28	7/16 - 20 X 1 3/8 in.
<input type="checkbox"/>	11	3017050	Captive Washer Cap Screw	4	5/16 - 24 X 2 1/8 in.
<input type="checkbox"/>	12	3068463	Oil Pan Gasket	1	